



HEIDENHAIN



CNC PILOT 4290 V.7

Software Function for B Axis

February 2007

The B Axis

– For Working in a Tilted Plane

The B axis makes it possible to drill, bore and mill in oblique planes. At first glance, programming for such operations seems very complex and compute-intensive. On the CNC PILOT, however, the programming is preceded by a coordinate transformation that makes it as easy as working in a main plane.

The B axis also provides benefits for turning operations. By tilting the B axis and rotating the tool you can bring it into positions that enable you to use a single tool to machine in the longitudinal and transverse directions on the main and opposing spindles. That allows you to reduce the number of tools needed as well as do without certain tool changes.

Programming

The usual separation of contour description and machining also applies to milling, drilling and boring operations on a tilted plane.

First you rotate and shift the coordinate system so that it lies in the tilted plane. Then you describe the hole pattern or the milling contour as you would in the YZ plane. Here you can use the hole pattern and figure definitions of the CNC PILOT. This means that, for linear or circular patterns and simple figures (circles, rectangles, regular polygons, etc.), you only need a few more entries to describe the pattern or figure on the tilted plane.

For boring and milling you move the tool to a position perpendicular to the tilted plane. Then you start cutting with the drilling, boring and milling cycles, using the same cycles as for the YZ plane. The CNC PILOT already has the required parameters of the tilted plane from the contour description.

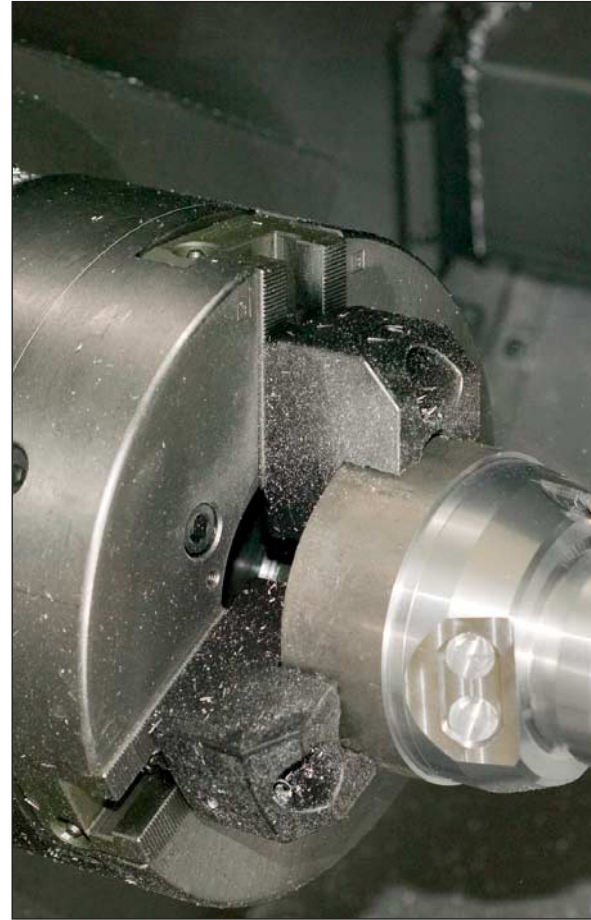

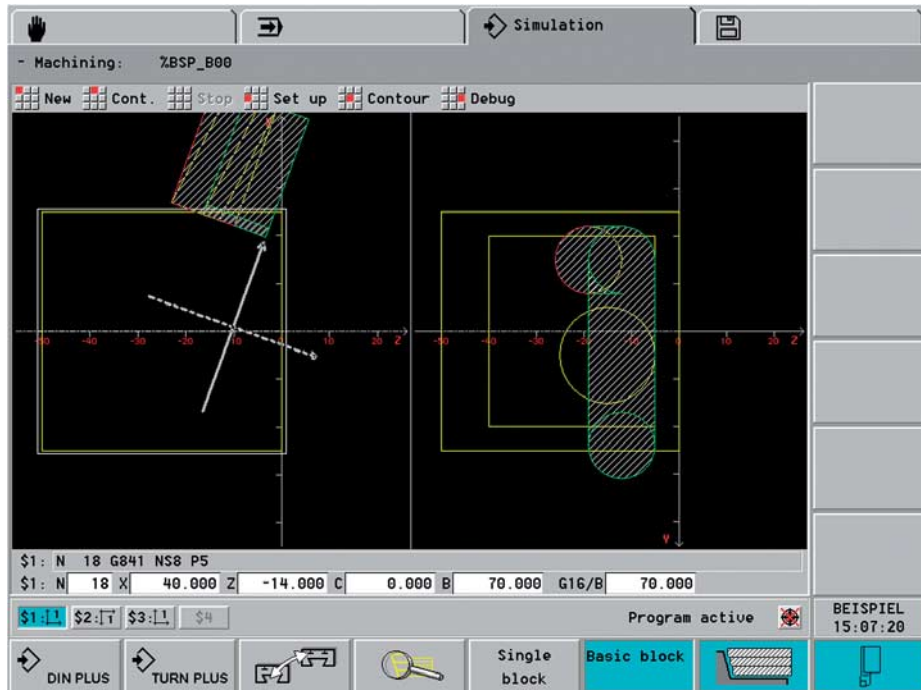

Simulation

In the Side View window, the simulation shows the hole pattern and milling contour perpendicular to the tilted plane—without distortion. This ensures simple verification of programmed hole patterns and milling contours. You also verify the tool movements in the Side View window. If you want to check the machining in the tilted plane with respect to the rotated

contour or the face, add the Lathe Window or Front Window. In the position display (below the simulation window), the CNC PILOT displays the angle of the tilted plane and the tilt angle in the B axis. And do you want to see the active coordinate system? No problem—with a simple keystroke the CNC PILOT shows the current datum and the direction of the active coordinate system.

– Flexible Use of Tools

Facing and...

Flexible use of tools*

If your machine is equipped with a B axis, you can use your tools much more efficiently than before. On conventional lathes you need four different tools for longitudinal and transverse turning on opposing spindles. With a B axis, you can do it with a single tool.

You simply tilt the B axis and rotate the tool to the normal position or for machining from behind the workpiece—whichever is required for longitudinal or transverse turning on the main or opposing spindle. All you need is a single call, the CNC PILOT calculates the tool lengths, the tool angle and the other tool data for you.

Tool-use flexibility is increased significantly when several tools are mounted in one holder. For example, with a roughing, finishing and recessing tool you can perform considerable parts of turning and recessing operations on a main and opposing spindle—without changing the tool. And programming is very easy. You simply indicate which tooth of the tool to use and then define the tilting angle and the tool position. And no more, because the CNC PILOT already has the rest position and the data of each tool tooth in its database.

This type of flexibility lowers the number of your tools, and you save machining time by reducing the number of tool changes.

* The machine and CNC PILOT must be adapted for this function.

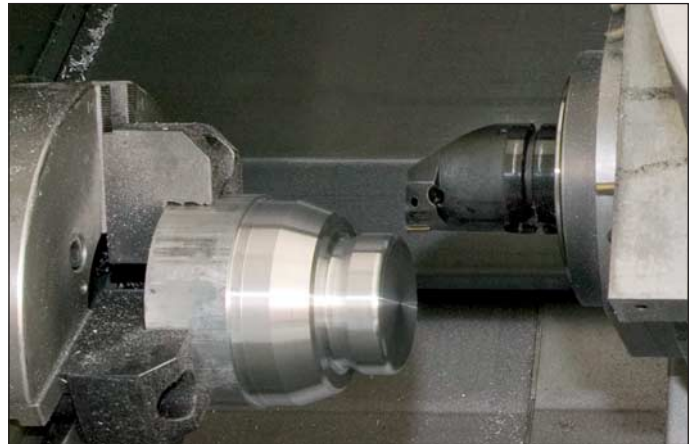

...longitudinal turning with the same tool...

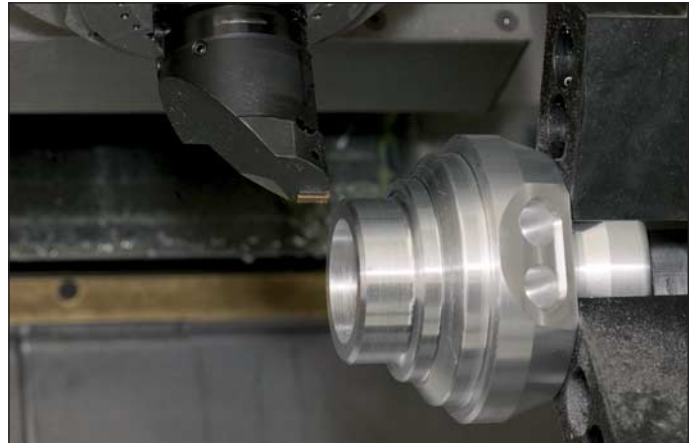

...and for several tools on one holder.

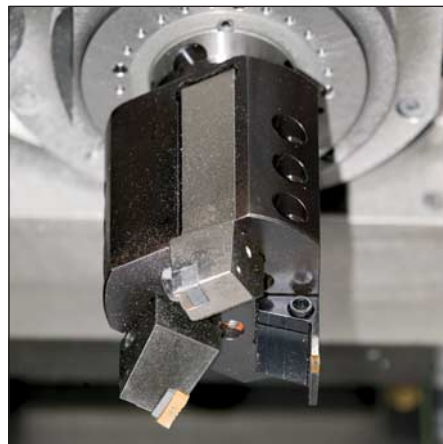

HEIDENHAIN

DR. JOHANNES HEIDENHAIN GmbH

Dr.-Johannes-Heidenhain-Straße 5

83301 Traunreut, Germany

☎ +49 (8669) 31-0

☎ +49 (8669) 5061

E-Mail: info@heidenhain.de

www.heidenhain.de

